

Photo Courtesy of
Design Dimension Inc.

PROJECT SNAPSHOT

Project Name:	QolorFLEX Light Box Installation at Olde Raleigh Distillery
Location:	Zebulon, North Carolina
Installation Completion:	February 2021
Client:	Olde Raleigh Distillery
Lighting Design/Fabrication:	Design Dimension Inc.
City Theatrical Solution(s):	QolorFLEX® Quad Chip RGBWW LED Tape (8 reels), QolorFLEX Connect 10s, Mean Well Power Supplies, QolorFLEX 5-Conductor Ribbons / Connectors



Family-owned and operated by master blender and distiller extraordinaire, Brandon McCraney, [Olde Raleigh Distillery](#) is located in the heart of downtown Zebulon, North Carolina and is known for its focus on the art of blending and distilling spirits in small-batch blends. The Olde Raleigh Distillery includes a Tasting Room, 61-foot neighborhood bar, and event space within its 10,000 square foot brick building.

CHALLENGES

As part of a renovation project at Olde Raleigh Distillery, the design and fabrication team from Design Dimension Inc. was looking to add a lighting element that would be an eye-catching centerpiece to bring light to a dark wall in the distillery, as well as become a place to display and store their merchandise. They came up with a design that included 184 real glass bottles in front of an LED light box - the perfect addition to add light, dimension and fun to the distillery space.

As the team began work on the project, they found that the most challenging aspect was creating a uniform glow, with no hot spots, over a large surface area. The client also wanted the ability to change color and match the existing lighting in the space. They knew that their ideal LED tape option for this project would not only provide even light and color from every LED to match the design specifications, but also offer color changing options and warm white color matching to fit the space.

SOLUTION

The design and fabrication team from Design Dimension Inc. chose [QolorFLEX Quad Chip RGB+Warm White LED Tape](#) (P/N 5050-24-Q-RGBWW-60-5-20-1) to meet the unique challenges of this installation, and installed eight reels of it into an aluminum channel with a milky diffuser pointed straight out at the viewer, thus creating large shadow box, to achieve the desired multidimensional look.

“The client wanted the ability to change color as well as match the existing lighting in the space. QolorFLEX Quad Chip RGBWW LED Tape was the right product for the job.”

- Andrew Domanski, Fabricator/Designer, Design Dimension Inc.



Photos Courtesy of Design Dimension Inc.



TESTING

The team explored the idea of edge lighting the shadow box but found that too much light faded away towards the middle of the box, making the glow non-uniform. To create a uniform glow without hot spots over the large surface area, they used two types of diffusing acrylic spaced away from the QolorFLEX Quad Chip LED tape in order to diffuse the glow and blend it together.

They created small scale prototypes to ensure all components would work in full scale, and use the right diffusing acrylics and distances from the LEDs for the ideal look.

The team installed the QolorFLEX Quad Chip RGBWW LED Tape in combination with QolorFLEX Connect 10s for a well organized installation of LED tape, power supplies, ribbon cables and connectors.

“It is a pleasure to work with QolorFLEX LED Tape, especially in combination with the QolorFLEX Connect 10s and other QolorFLEX accessories.”

- Andrew Domanski, Fabricator/Designer, Design Dimension Inc.



QolorFLEX Quad Chip RGBWW LED Tape

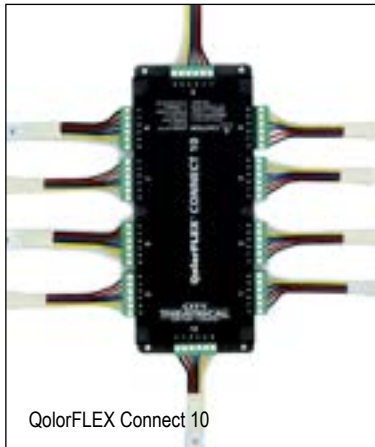

QolorFLEX Connect 10

Between the shadow box, acrylic, hardware, LED tape and 184 glass bottles, the weight of the final installation was a combined 300+ lbs. - all suspended as a single assembly on the wall. The team opted to add a steel “stiff knee” that matched the legs of the surrounding casework to support most of the weight.

For more information on QolorFLEX, visit:

www.citytheatrical.com/qolorflex

**CITY
THEATRICAL**
NEW YORK • LONDON